

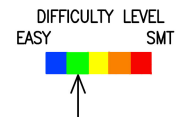

QRPBuilder LMP7721 ELF/VLF Pre-amp Kit

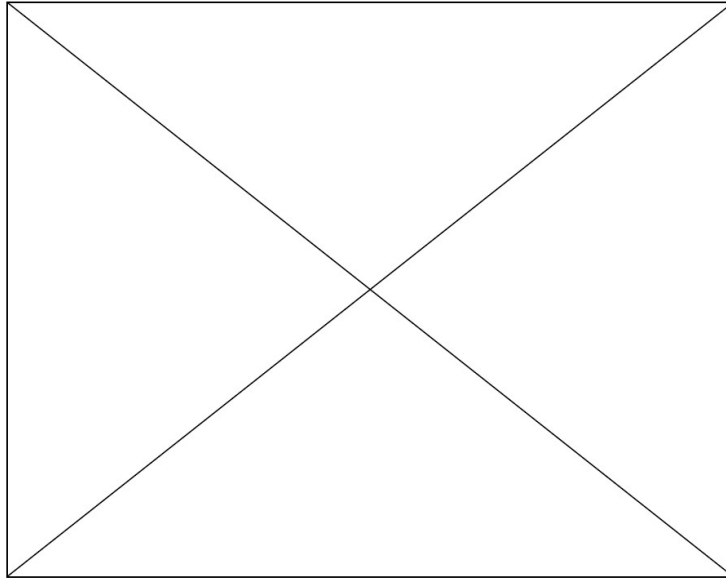

First, familiarize yourself with the parts and check for all the components. If a part is missing, please contact us at qrpbuilder@gmail.com and we will send you one.

Parts List

- 1 – QRPBuilder LMP7721 ELF Preamp pcb
- 1 – U2, LMP7721 OpAmp
- 1 – U2, 78L05 voltage regulator
- 1 – D1, LED
- 1 – R1, 10K resistor (brown-black-orange-gold)
- 1 – R2, 1G resistor (brown-black-gray-gold)
- 2 – R3,4, 1M resistor (brown-black-green-gold)
- 1 – R5, 22 ohm resistor (red-red-black-gold)
- 1 – R6, 10 ohm resistor (brown-black-black-gold)
- 1 – R7, 47K resistor (yellow-violet-orange-gold)
- 5 – C1,3,4,6,7, .1uF MLCC marked 104
- 1 – C2, 10uF electrolytic capacitor
- 1 – C5, 470 uF electrolytic capacitor
- 1 – C8, 1000uF electrolytic capacitor
- 1 – NE-2 neon bulb
- 1 – T1, 600:600 ohm audio transformer
- 1 – J2, RJ45 female pcb jack
- 1 – S1, 1x3 SIP
- 1 – J3, 1x5 SIP
- 1 - Berg connector (jumper)
- 1 – 9V battery clip-female, Mouser #534-594
- 1 – 9V battery clip-male, Mouser #534-593
- 1 – 2 position terminal block

Using the component placement graphic guide below, start assembling and check off as you go.

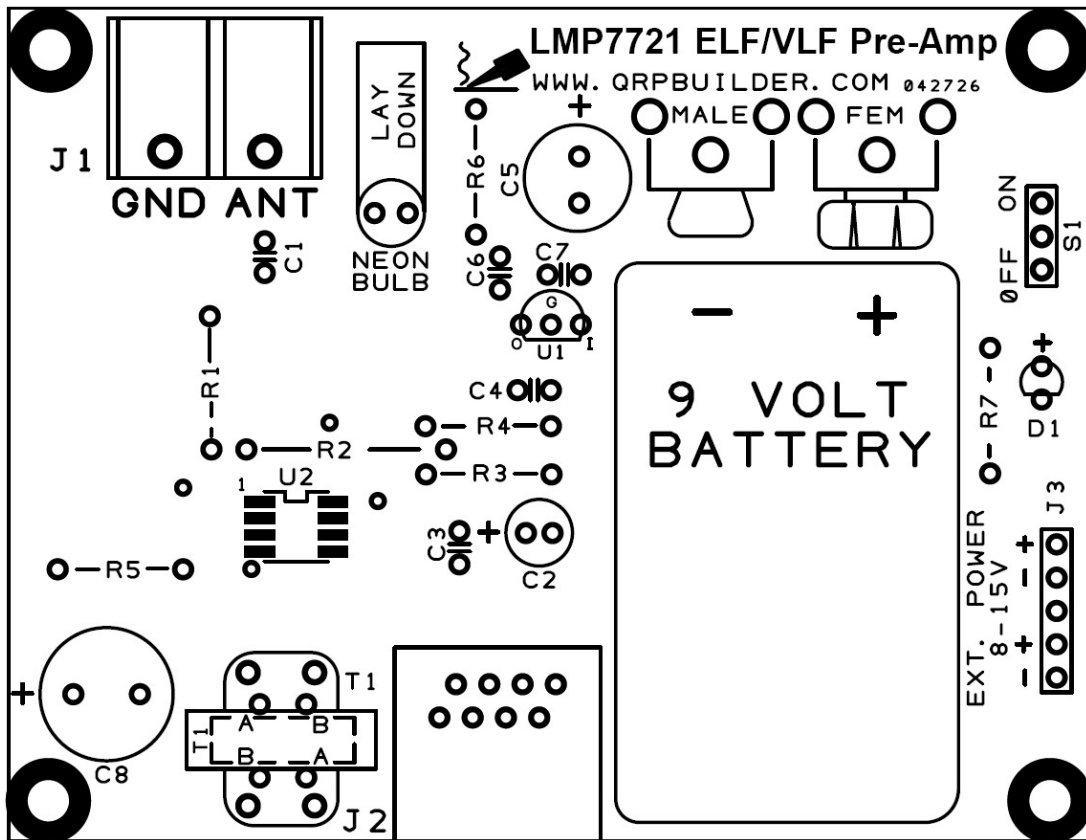

- [] Install U2, LMP7721 SOIC OpAmp, *match the board outline for pin1*

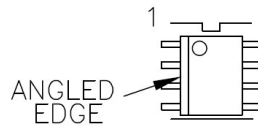

- [] Install R1, 10K resistor (brown-black-orange-gold)
- [] Install R2, 1G resistor (brown-black-gray-gold)
- [] Install R3,4, 1M resistor (brown-black-green-gold)
- [] Install R5, 22 ohm resistor (red-red-black-gold)
- [] Install R6, 10 ohm resistor (brown-black-black-gold)
- [] Install R7, 47K resistor (yellow-violet-orange-gold)
- [] Install C1,3,4,6,7, .1uF MLCC marked 104
- [] Install D1, LED, *observe polarity, the long lead is “+”*
- [] Install U1, 78L05 voltage regulator, *match the board outline*
- [] Install C2, 10uF electrolytic capacitor, *long lead is “+”*

- [] Install C5, 470 uF electrolytic capacitor, *long lead is “+”*
- [] Install C8, 1000uF electrolytic capacitor, *long lead is “+”*
- [] Install NE-2 neon bulb, lay down
- [] Install S1, 1x3 SIP
- [] Install J3, 1x5 SIP
- [] Install J2, RJ45 female pcb jack
- [] Install 9V battery clips, as shown below. *Do not mix them up.*

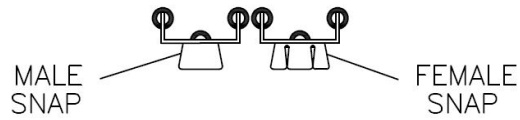

- [] Install T1, 600:600 ohm isolation transformer
- [] Install J1, 2 position terminal block

This completes the assembly

Schematic:

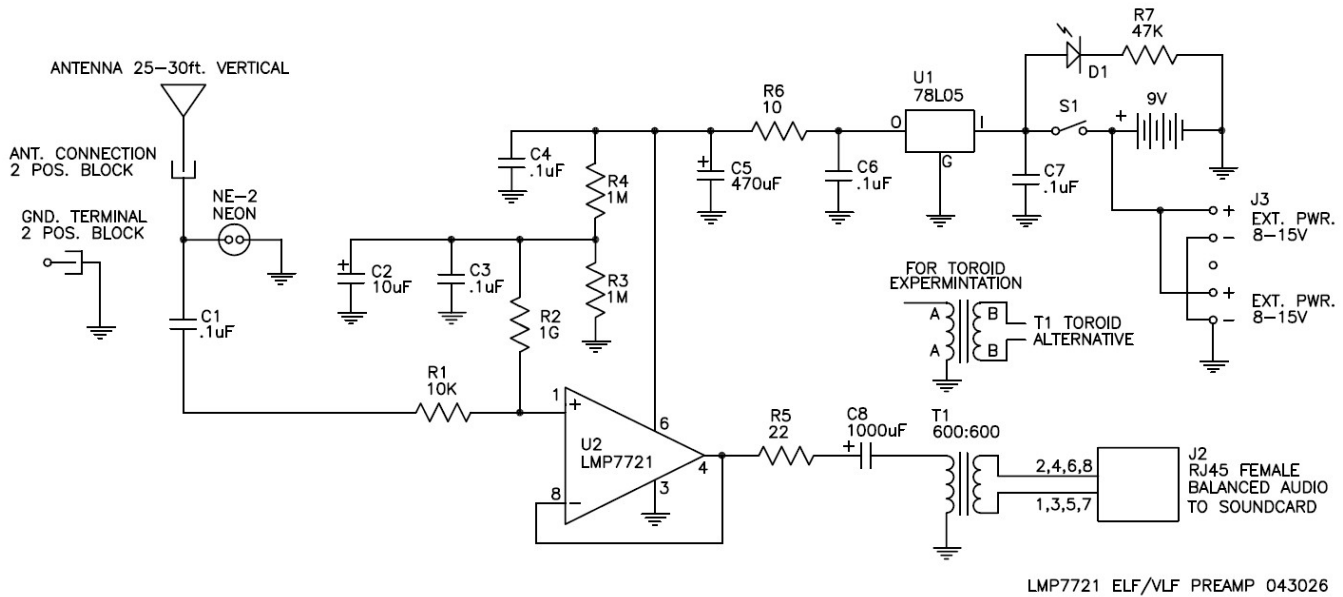

The basic design was originated by DK7FC, later modified by VK2AN to include the balanced audio output and component value changes to improve frequency response. This schematic varies only from VK2AN's post in that R1 has changed from 1Meg to 10K. He reports an improved frequency response to 80KHz, using a readily available 600:600 transformer.

Installation and usage considerations.

The preamp can be used portable, with the 9v battery on the board or in permanent remote installation with a rechargeable battery and solar charger

Choose an antenna location carefully, as far away from domestic power lines or any other domestic powered devices as possible. The antenna can be a fiberglass squid pole with a 20-30ft. wire or a wire supported by the top of a tree. Keep the base away from the trunk as it will absorb the type of signals you are trying to receive.

For a permanent setup, mount the pre-amp in a waterproof box at the antenna base pipe. Use a ground stake at the antenna base and ground the board.

There are provisions to power the board with the external power pads on the pcb with a detached battery and charged with a solar panel. The current draw is very low, <5mA. Size your batteries and solar panel so a charge controller is not necessary. Avoid a charge controller, as they can generate interference. Or, you could use a small panel with one of the 9V LiPo batteries with LM78L09 regulator.

The audio output is via the RJ45 connector for the balanced audio output to your soundcard. The pcb has the RJ45 lines (2,4,6,8) tied together for one side, and the white striped lines (1,3,5,7) are tied together for the other side for the balanced audio output. The cat5 multiple line pairing, allows for longer runs of the cable (100m or more), preferably underground.

My ELF/VLF experience is limited to only using this pre-amp fed to a Behringer UMC202HD external USB sound card with the DL4YHF Spectrum Labs Audio Spectrum Analyzer, Jul 30 2025.

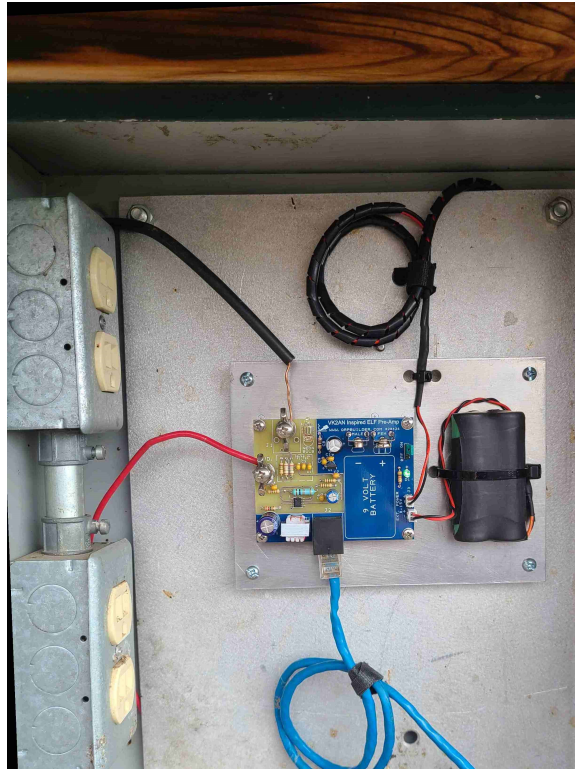

This antenna is a 22ft. long vertical. The board powered with a couple of 18650 LiPo batteries in series, charged with the solar panel. The cat5 run to the shack is about 200ft, run underground. Further observations:

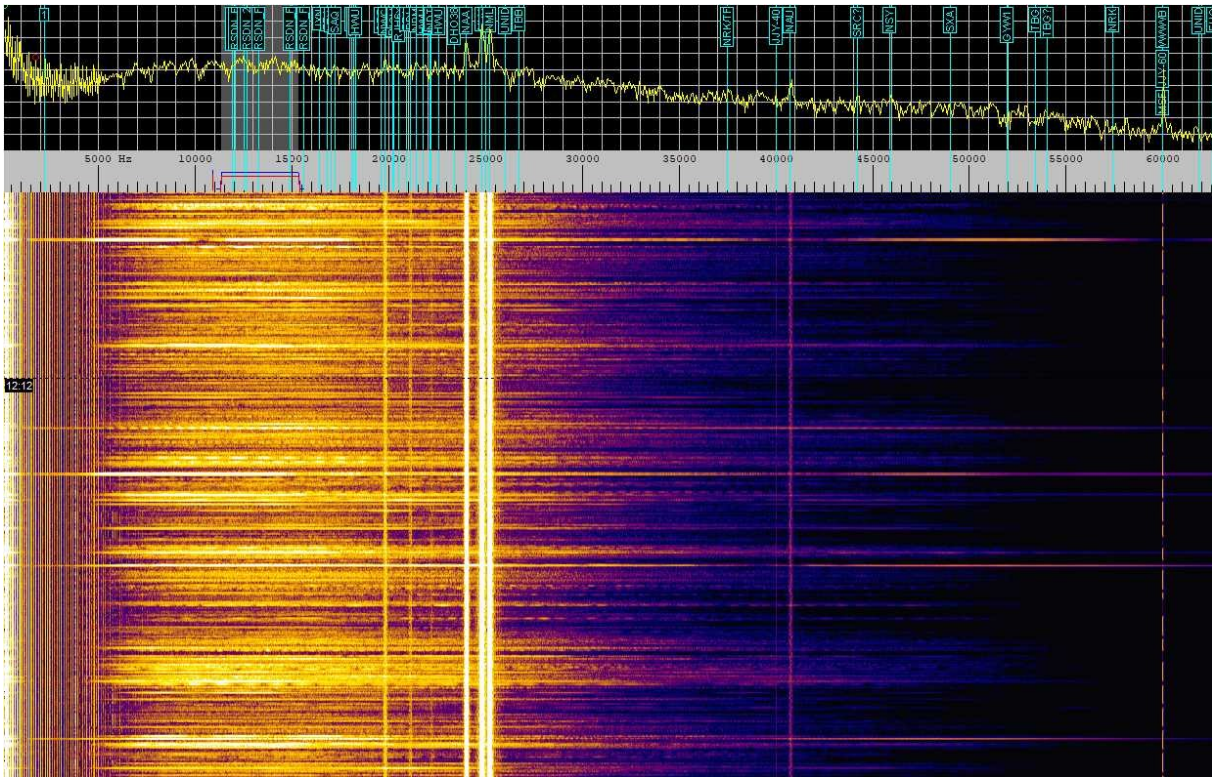

This is a screenshot of the spectrum showing the improved frequency response to 80KHz.

My setup and additional usage notes as of 042826:

The LMP7721 ELF/VLF Pre-amp board, with the balanced audio output fed the XLR input of a Behringer UMC202HD Audio interface to the usb port on a Windows 11 computer, running the latest version of the Spectrum Labs Audio Analyzer program.

Spectrum Labs Audio Analyzer, V3.1 b3 (2025-07-26)
Behringer UMC USB Audio Driver, v. 5.72.0

To get the full frequency response from the UMC202HD, set SpecLabs audio as shown below:

- Audio Processing Rate – 192000hz
- Set Input device – Behringer UMC202HD
- Set Output Device – Your speakers

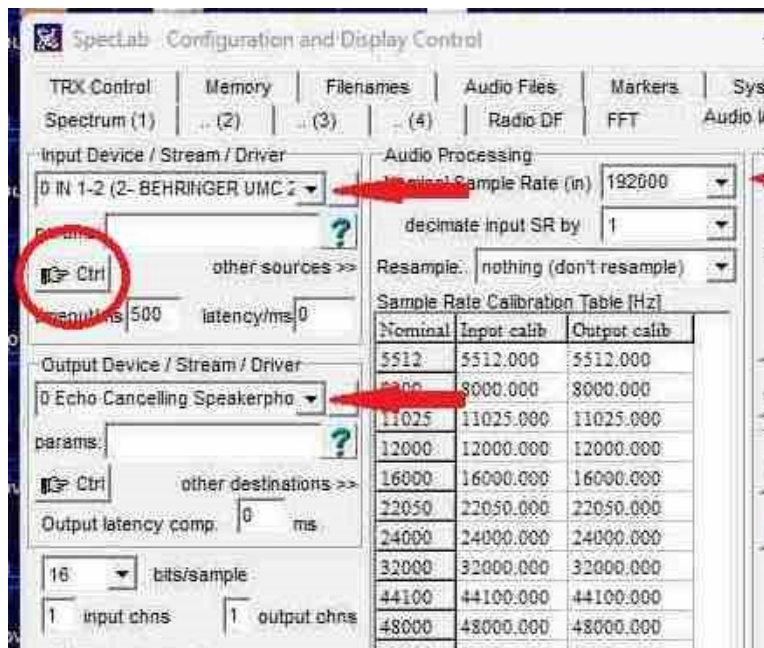

Next, In the same window select Hand Ctrl icon in the Input Device and the Windows Sound Properties will appear. Select Behringer, then properties, advanced, and set the bit rate to 24bit, 192000hz., apply. This setting in Windows sound screen must be done when the SpecLabs program is open.

