

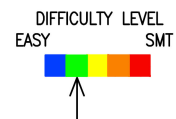

## QRPCoder VK2AN ELF Pre-amp



### Parts List

- \*1 – QRPCoder VK2AN ELF Preamp pcb
- \*1 – U2, LMP7721 OpAmp
- 1 – U2, 78L05 voltage regulator
- 1 – D1, LED
- 1 – R1, 10K resistor (brown-black-orange-gold)
- \*1 – R2, 1G resistor (brown-black-gray-gold)
- 2 – R3,4, 1M resistor (brown-black-green-gold)
- 1 – R5, 22 ohm resistor (red-red-black-gold)
- 1 – R6, 10 ohm resistor (brown-black-black-gold)
- 1 – R7, 47K resistor (yellow-violet-orange-gold)
- 5 – C1,3,4,6,7, .1uF MLCC marked 104
- 1 – C2, 10uF electrolytic capacitor
- 1 – C5, 470 uF electrolytic capacitor
- 1 – C8, 1000uF electrolytic capacitor
- \*1 – NE-2 neon bulb
- \*1 – T1, 600:600 ohm audio transformer
- \*1 – J2, RJ45 female pcb jack
- \*1 – S1, 1x3 SIP
- \*1 – J3, 1x5 SIP
- \*1 - Berg connector (jumper)
- \*1 – 9V battery clip-female, Mouser #534-594
- \*1 – 9V battery clip-male, Mouser #534-593
- 2 – 8-32 S.S. captive hardware
  
- \* – supplied with the partial kit

Using the component placement graphic guide below, start assembling and check off as you go.

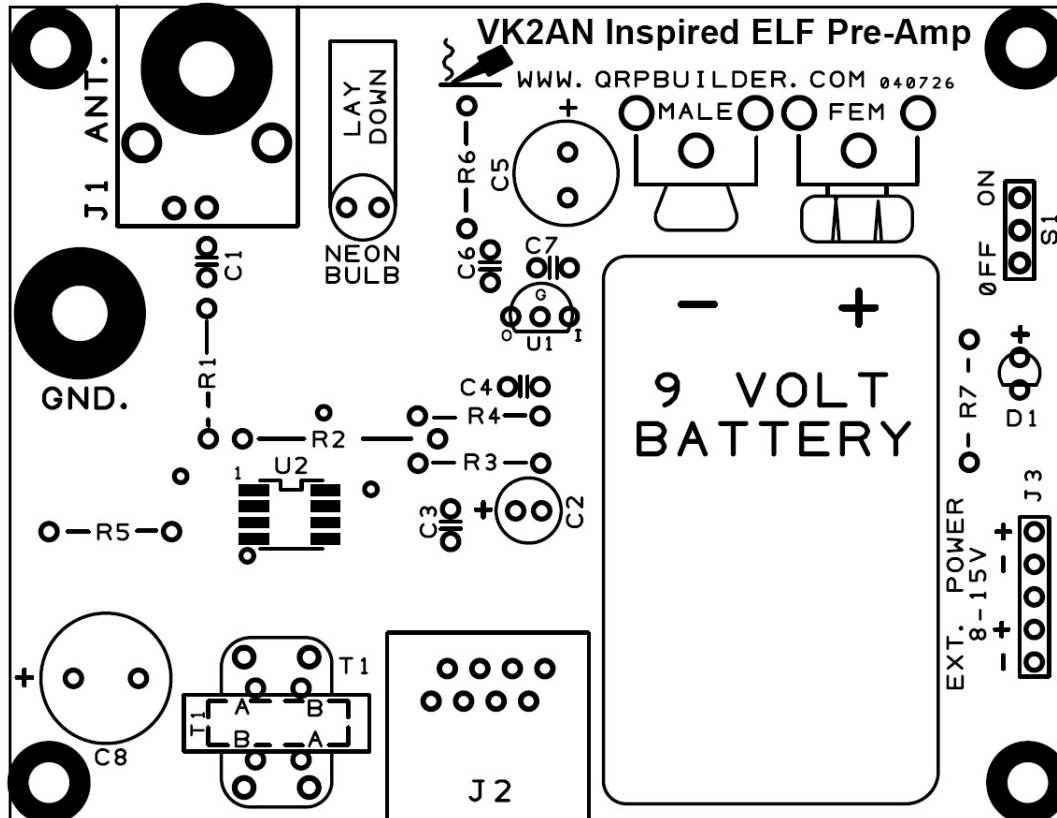

- [ ] Install U2, LMP7721 SOIC OpAmp, *match the board outline for pin1*

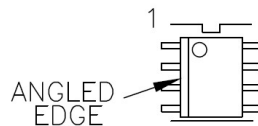

- [ ] Install R1, 10K resistor (brown-black-orange-gold)
- [ ] Install R2, 1G resistor (brown-black-gray-gold)
- [ ] Install R3,4, 1M resistor (brown-black-green-gold)
- [ ] Install R5, 22 ohm resistor (red-red-black-gold)
- [ ] Install R6, 10 ohm resistor (brown-black-black-gold)
- [ ] Install R7, 47K resistor (yellow-violet-orange-gold)
- [ ] Install C1,3,4,6,7, .1uF MLCC marked 104
- [ ] Install D1, LED, *observe polarity, the long lead is "+"*
- [ ] Install U1, 78L05 voltage regulator, *match the board outline*
- [ ] Install C2, 10uF electrolytic capacitor, *long lead is "+"*

- [ ] Install C5, 470 uF electrolytic capacitor, *long lead is “+”*
- [ ] Install C8, 1000uF electrolytic capacitor, *long lead is “+”*
- [ ] Install NE-2 neon bulb, lay down
- [ ] Install S1, 1x3 SIP
- [ ] Install J3, 1x5 SIP
- [ ] Install J2, RJ45 female pcb jack
- [ ] Install 9V battery clips, as shown below. *Do not mix them up.*

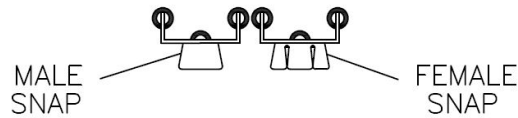

- [ ] Install T1, 600:600 ohm isolation transformer
- [ ] Install the 8-32 SS ground wingnut assembly at the ground connection position as shown in the graphic below.

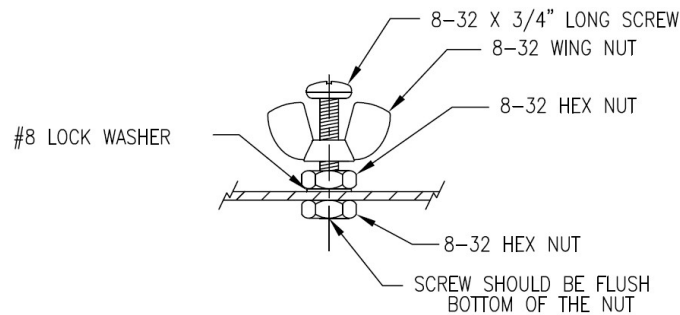

- [ ] Attach the four rubber feet where indicated on the backside silkscreen or mount in your enclosure.

This completes the assembly

## Schematic:

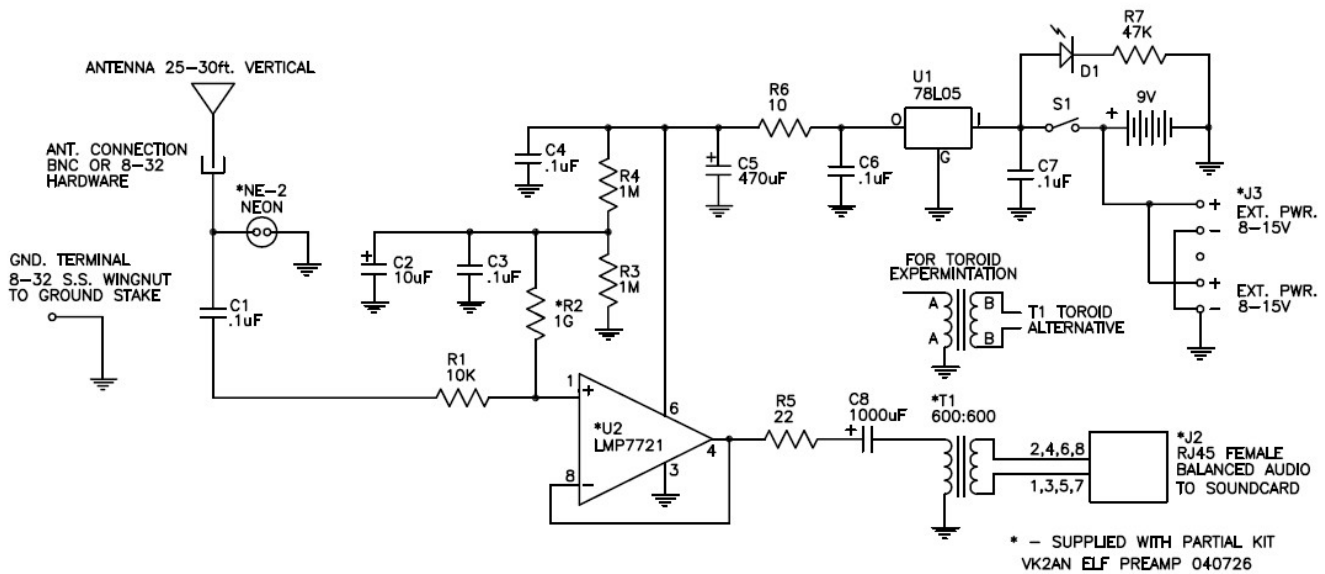

This schematic varies only from Peter's original post in that R1 has changed from 1Meg to 10K. He reports an improved frequency response to 80KHz.

Installation and usage considerations.

The preamp can be used portable, with the 9v battery on the board or in permanent remote installation with a rechargeable battery and solar charger

Choose an antenna location carefully, as far away from domestic power lines or any other domestic powered devices as possible. The antenna can be a fiberglass squid pole with a 20-30ft. wire or a wire supported by the top of a tree. Keep the base away from the trunk as it will absorb the type of signals you are trying to receive.

For a permanent setup, mount the pre-amp in a waterproof box at the antenna base pipe. Use a ground stake at the antenna base and ground the board.

There are provisions to power the board with the external power pads on the pcb with a detached battery and charged with a solar panel. The current draw is very low, <5mA. Size your batteries and solar panel so a charge controller is not necessary. Avoid a charge controller, as they can generate interference. Or, you could use a small panel with one of the 9V LiPo batteries with LM78L09 regulator.

The audio output is via the RJ45 connector for the balanced audio output to your soundcard. The pcb has the RJ45 lines (2,4,6,8) tied together for one side, and the white striped lines (1,3,5,7) are tied together for the other side for the balanced audio output. The cat5 multiple line pairing, allows for longer runs of the cable (100m or more), preferably underground.

My ELF/VLF experience is limited to only using this pre-amp fed to a Behringer UMC202HD external sound card with Spectrum Labs V3.1 b3.

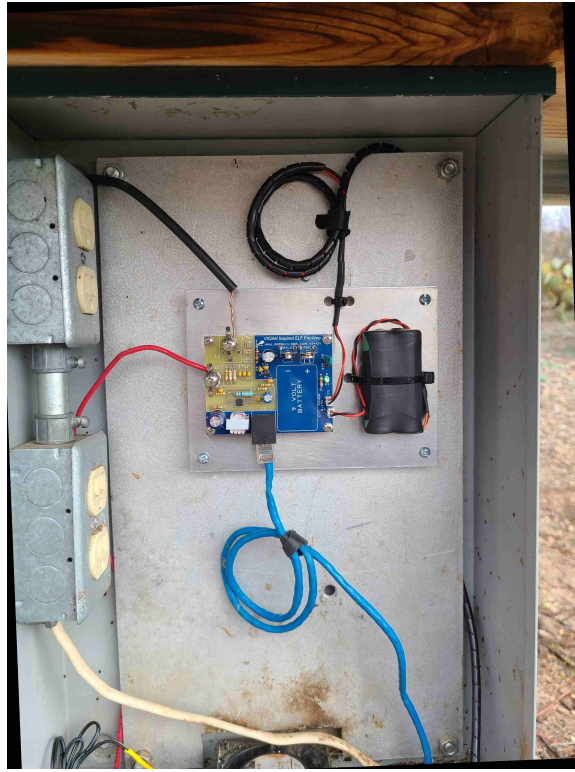

This antenna is a 22ft. long vertical. The board powered with a couple of 18650 LiPo batteries in series, charged with the solar panel. The cat5 run to the shack is about 200ft, run underground. Further observations:

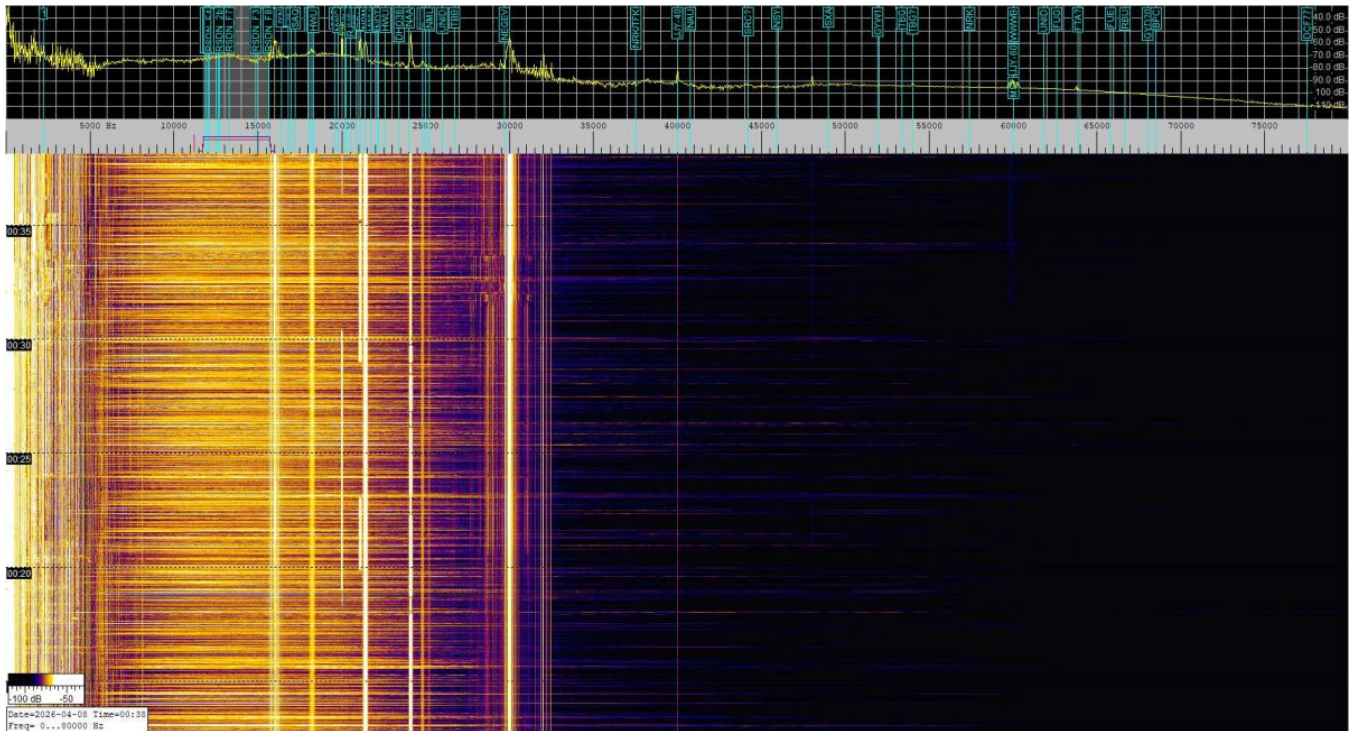

This is Peter's SpecLab screenshot of the spectrum showing the improved frequency response to 80KHz with pcb I sent him.

