

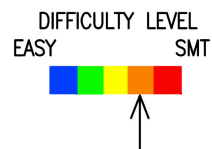

QRPBuilder Iambic SODA Mini Paddle kit

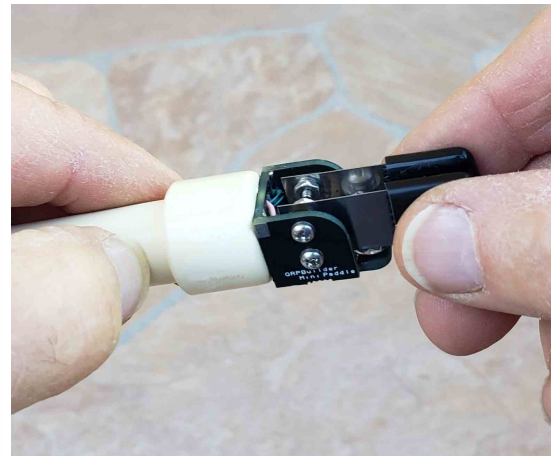
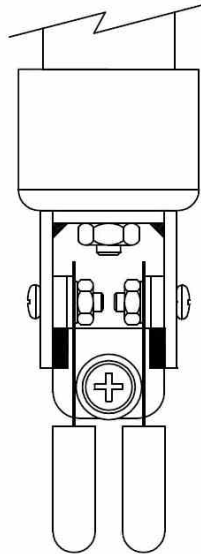

First, familiarize yourself with the parts and check for all the components. If a part is missing, please contact us and we will send one. Email qrpbuilder@gmail.com to request a part, or for any questions.

Parts List

- 1 – QRPBuilder Iambic SODA Mini Paddle PCB
- 4 – 2-56 x 5/16”L SS Phillips head screw
- 4 - #2 SS lock washer
- 4 – 2-56 SS nut
- 2 – 4-40 x 7/16”L SS pan head Phillips screw
- 2 – #4 SS flat washer
- 1 - #4 SS lock washer
- 3 – 4-40 brass nut
- 4 - #2 x .06” thick nylon washer
- 4 - #2 x .03” thick nylon washer
- 1 - #4 x .19”L nylon spacer
- 1 – 4-40 x 1”L SS pan head Phillips screw
- 2 – SS paddle leaf
- 1 - 1/2” wide x 3”L plastic shim
- 2 - 1/2” x 1” vinyl Caplug
- 1 – 1/2” CPVC tube 4” long
- 1 – 1/2” CPVC cap
- 1 – 3.5mm stereo plug
- 1 – Ø 5/8” x 1/2” long vinyl Caplug
- 1 – sm. plastic tyrap

Even if you have done radio kit assembly before, please read through all the instructions before you start. This kit is a little different, in that the mechanical components are parts of a printed circuit board. The instructions give you the scope of the project and an understanding of the techniques we have employed. You will be assembling the paddle from PCB material, and when assembled, also forms the electrical connections. There are solder pads and registration marks that must be observed so that when you tack and solder, it will make a sturdy mechanical and electrical assembly. The tools you will need are a soldering iron with a small tip, rosin core solder, a small Phillips screwdriver, needle nose pliers, tweezers for the small 2-56 screws and hardware, and a flat surface to work on.

The board is shown below. Break the board into the individual pieces, discarding the center connecting spine. You may need to hold the spine with a needle nose pliers. If there are any protruding bits of pcb protruding below flat surfaces at the break points (shown in red), rub the edge on some fine emery paper or an emery board to insure those edges are flat.

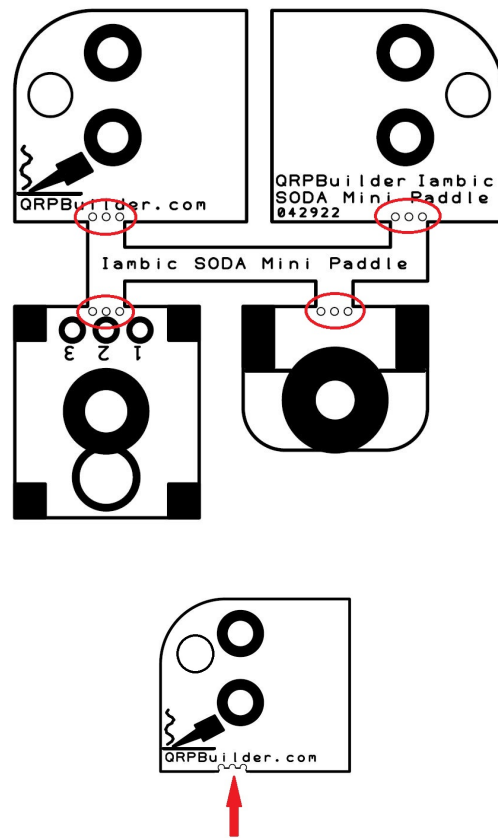

None of these 4 break areas should protrude beyond the edge of any of the boards. If they do, lightly rub on a piece of emery paper or emery board if needed. A light touch is all that is required. Like shown below.

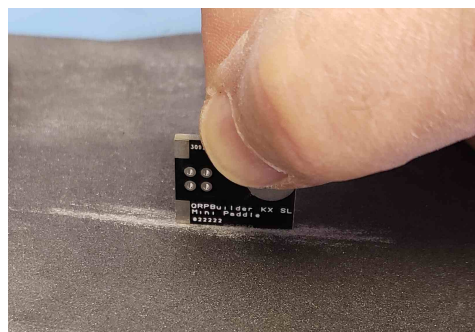

These are the four pieces and the names we will be using during the assembly. Notice that the contact holder is marked with registration lines. They will guide you when they are in the correct alignment.

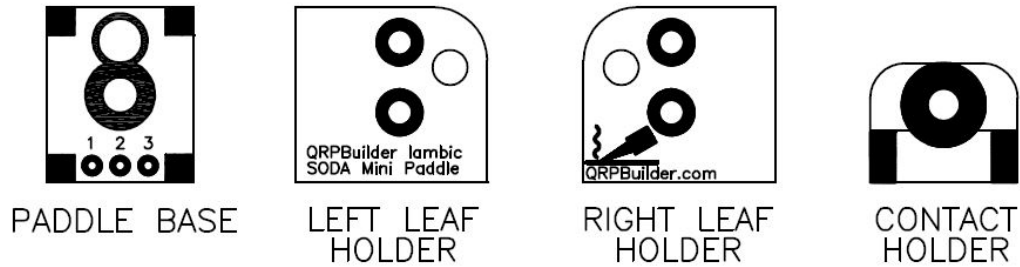

Important:

On all the soldering you do, you will use the same technique. You tack a single tiny point first and, then check to see that it is square and aligned with the registration lines and other notes. It is easy to re-heat the joint and adjust the alignment when there is only a single point. Then you tack the other pads, before you do the finish soldering. If you try to adjust without heating the joint, you will lift the pad off the board and ruin it.

The first three pieces to be joined are the **left leaf holder** and **right leaf holder**, with the **contact holder**. Use the 4-40 x 1" screw, three 4-40 nuts, left leaf holder and, the right leaf holder. Position them as shown in the figure below on a flat surface with the screw in the unplated hole. You must adjust the nuts so that the support just does fit between the two contact holders. A light slip fit is desired. You can position the Paddle Base to check that you do not have the leaf holders too tight to prevent the positioning of the Paddle Base. Align the silkscreened line with the front edge of both leaf holders. When you are satisfied with the alignment and squareness, lightly tack the two sides of the leaf holders to the contact holder. **Leave the screw and nuts in place for now.**

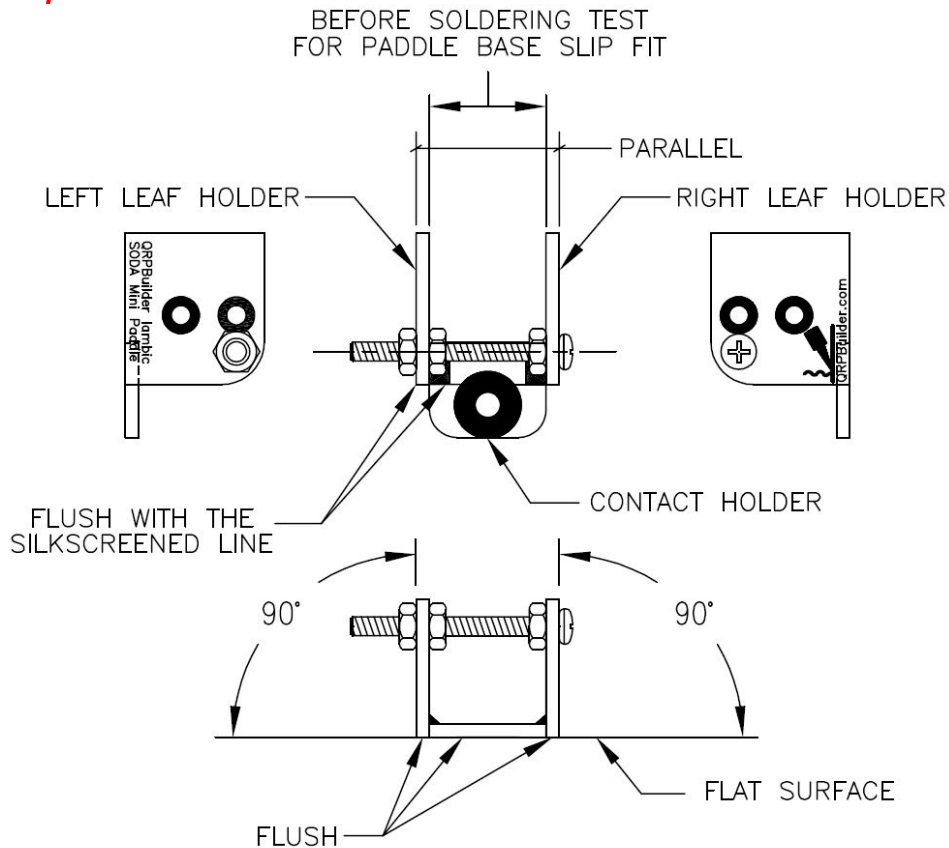

Mate the previous assembly to the Paddle Base as shown in the figure below. The Paddle Base should be a slip fit between the two leaf holders. Tack one small joint and check for alignment. When you are satisfied with the alignment, lightly tack all the other points. Finish soldering all the pads, including the joints between the leaf holders and the Contact Holder. You may now remove the 4-40 screw and nuts.

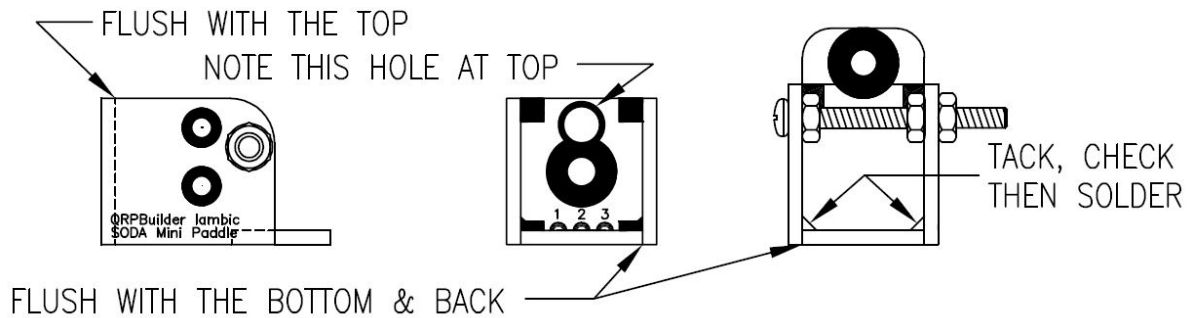

Solder the 4-40 brass nut to the contact holder using the figure below as a guide. It is helpful to rub the brass nut on some scotchbrite or emery paper to remove any oxidation from the brass. Use the hardware as shown in the figure to hold it in place. **The lock washer ensures the nut is square with the surface of the PCB when heated. Position the nut flats as shown.** Heat the nut from the side, and solder the brass nut to the contact support. Do not get any solder on the top of the nut. If you do, it must be cleaned off. Remove the holding screw and lock washer.

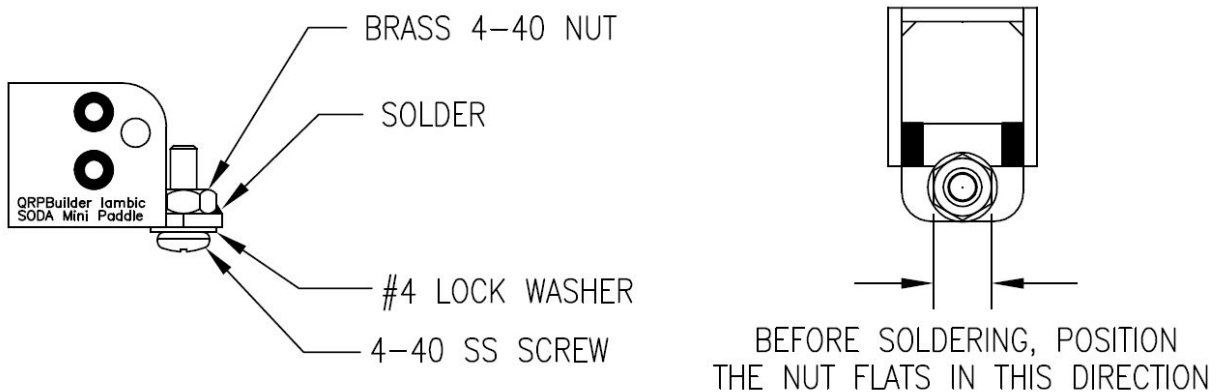

Solder the brass nut to the inside of the Paddle Base as shown below. Then remove the screw and L.W.

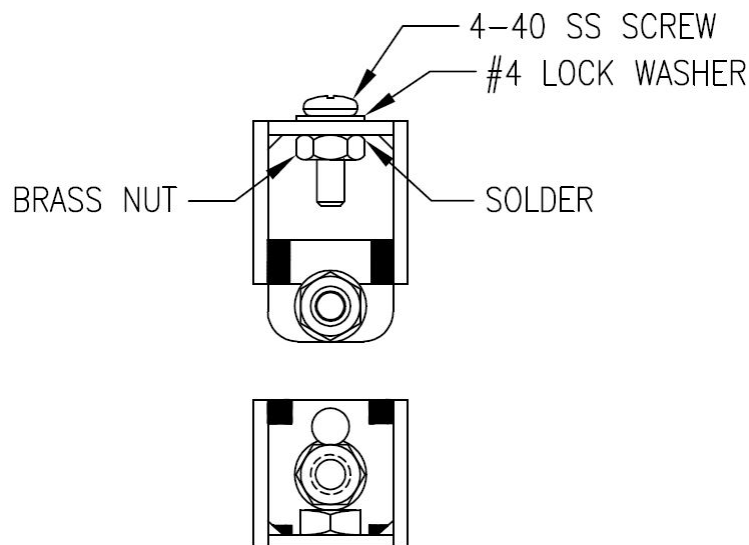

Assembling the paddle lever components:

It's a good idea to assemble the hardware over a cookie sheet. Any hardware is difficult to find if dropped. Secure the paddle leaves to the holders using the hardware as shown in the figure below. The hardware is small but with some patience and tweezers, can be assembled. It is easier to do the bottom screws first. Observe the order of the hardware.

Cut the vinyl Caplug lever cover 5/8" long from the closed end with scissors or a razor knife. Cut the piece of 1/2" wide plastic into two 1/2" long pieces. Sandwich the paddle lever between the plastic spacers and slide the Caplug over the end of the paddle leaf. You may opt to use some adhesive if they are not tight enough.

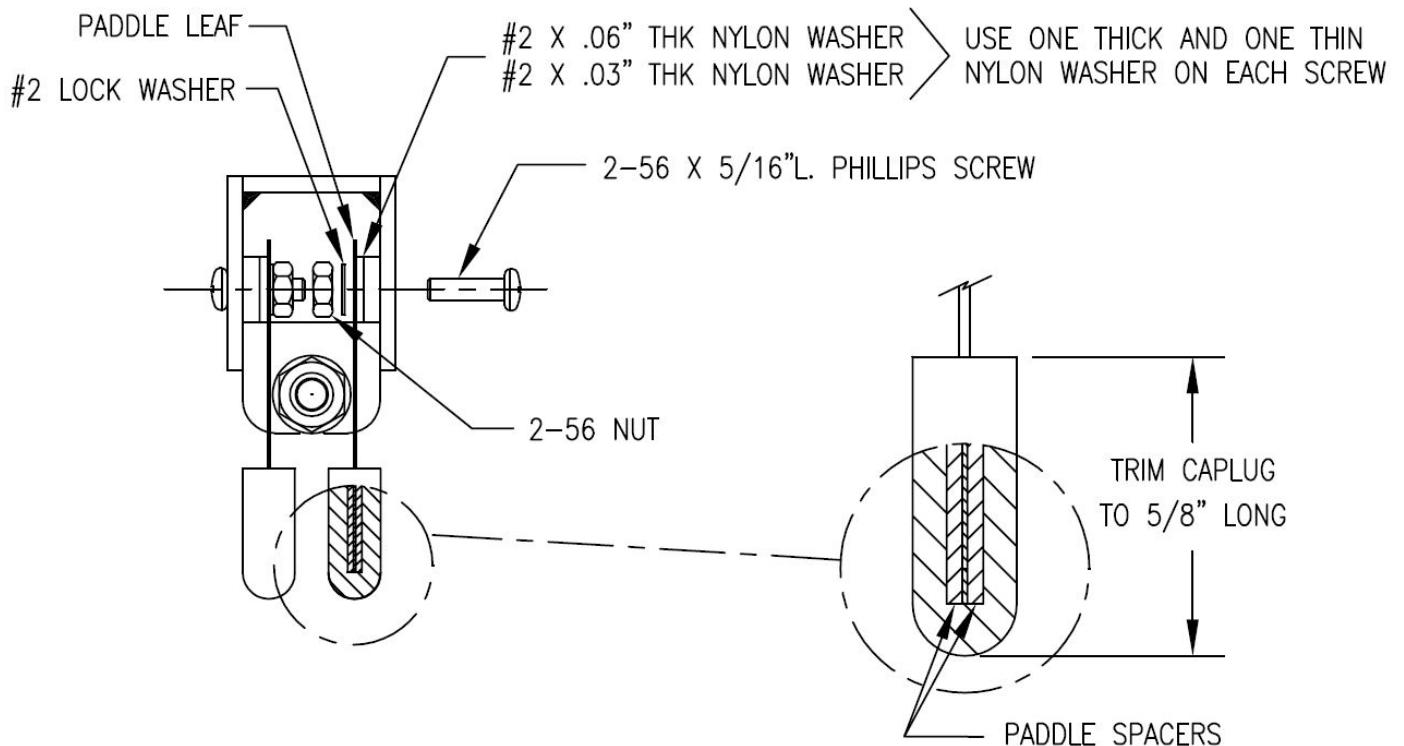

Assembling the center contact:

The center contact is assembled as shown in the figure below.

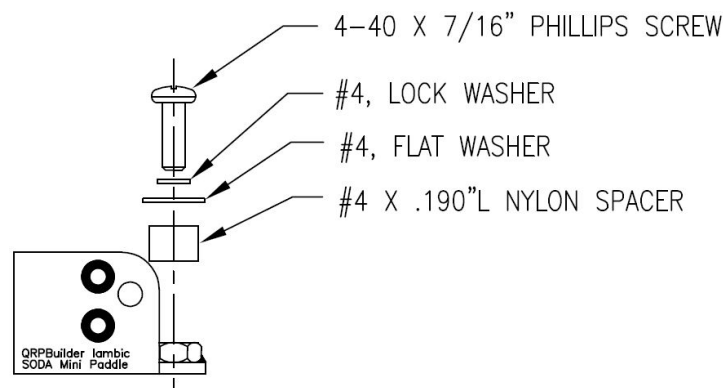

After assembly, if the paddle leaves may not be perfectly centered, the paddle leaf may be off to one side, or on an angle. Carefully bend it to be close to the contact washer. The distance to the contact washer is a

matter of personal preference and feel, and may need final adjustment after some practice. The hole in the center of the washer is a little larger than the holding screw, and permits some centering adjustment as well. The paddle leaves can easily be bent to accommodate different tensions and distances. The .010" thickness of the paddle leaf provides a light touch. A user could make a leaf with thicker shim stock material for a stiffer touch.

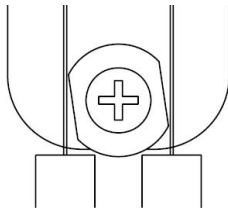

Note: You may opt to use a different diameter washer of your own choosing. For the adventurer, you could experiment with a larger washer with some flats filed on it for a different feel and or spacing.

Also, if you desire a stiffer feel or a lighter touch to the paddle, you can experiment with different paddle leaf thicknesses. You can easily make a set of leaves from a simple set of feeler gauges. Most auto parts stores or Harbor Freight carry an inexpensive set of 1/2" wide gages up to .030" thick.

This completes the mechanical of the paddle..

Electrical and final assembly

We do not supply the wire from the paddle to the rig. However we do supply a male 3.5mm stereo plug. You can also use one of the many 3.5mm m/m stereo jumpers you may have laying around, just cut one end off and wire it, or simply do like I did and braid three #26awg stranded wires together. Expose the 3 leads on your cable or wire approximately 3/4", and strip and tin the three leads ~1/8".

With your soldering iron melt a clearance hole for the wire in the center of the vinyl Caplug. Route the three wires first thru the outside of the Caplug, CPVC tube, inside of the CPVC cap, through the offset hole in the rear of the Paddle Base, around the brass nut, and into the pcb pads from the inside. After soldering, trim flush on the outside of the paddle assembly.

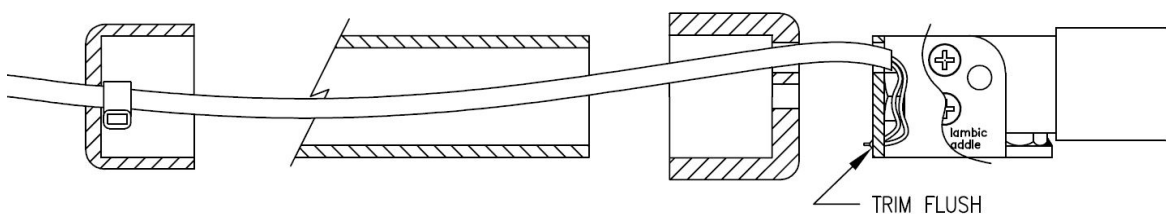

The three connection numbers are silkscreened on the inside of the Paddle Base as 1,2,3. Pad #2 is the common (ground). Pad #1 has continuity to ground when the right paddle is moved to the left. Pad #3 has continuity to ground when the left paddle is moved to the right. Choose whichever colors you wish for the three connections, and connect to the 3.5mm male plug as you wish to accommodate your transmitter.

You can now install the 4-40 x 7/16"L screw and washer on the inside of the cap as shown below to secure the CPVC cap to the paddle body. Make sure the wire clearance holes align. It is recommended that you do not cement the CPVC tube to the CPVC cap. It will easily lock in place with just a twist, so you can remove it if necessary. Install the tyrap on the cable on the inside of the Caplug as a strain relief.

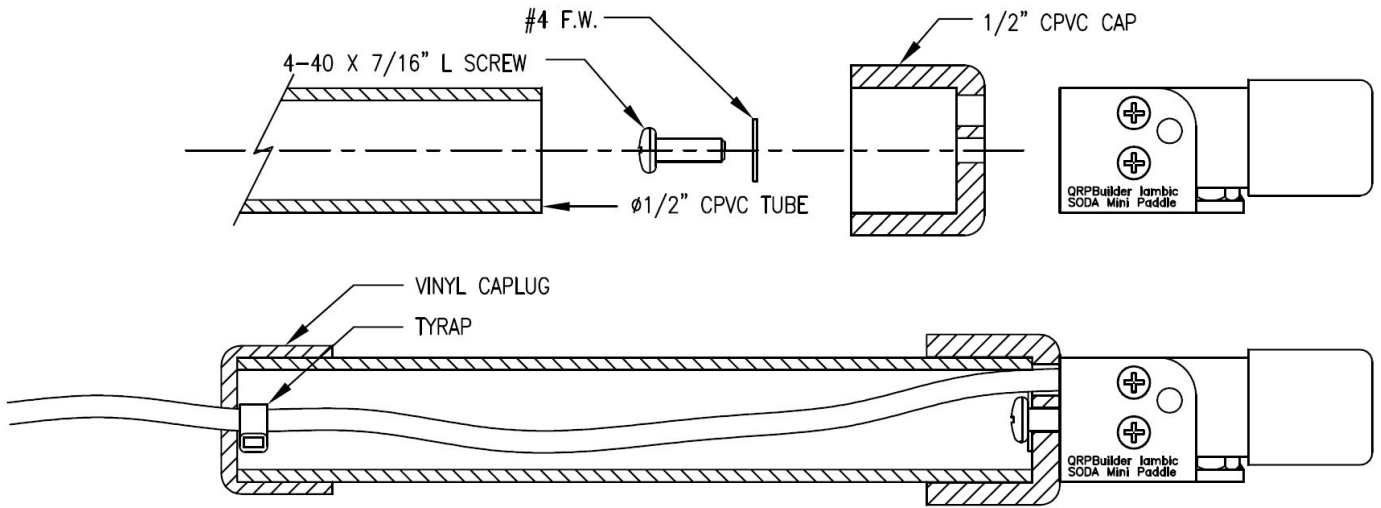

There is plenty of tube length to leave as is, or shorten to a desired length.

Notes:
